

Ⓐ

- NOTES: 1. FOR USE WITH PANDUIT MS63T15-CR4 & MS63T15-CR6 CONTINUOUS STRAPPING.
2. APPLICATION TOOL: BT2MS75, BT2HT
3. DIMENSIONS IN BRACKETS [ ] ARE IN MILLIMETERS
4. UNLESS OTHERWISE SPECIFIED TOLERANCES ARE:  
 .XX = ±.02 [ .5 ]  
 .XXX = ±.010 [ .25 ]
5. MATERIAL: 304 OR 316 STAINLESS STEEL

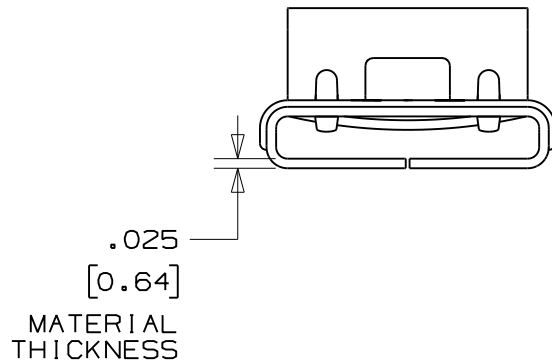
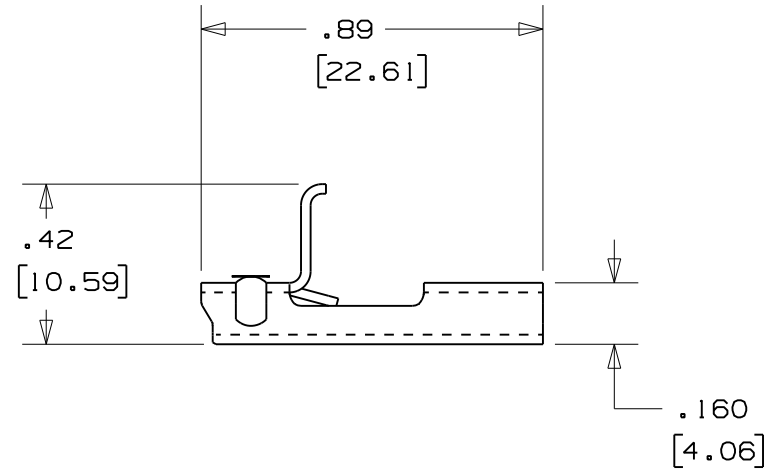
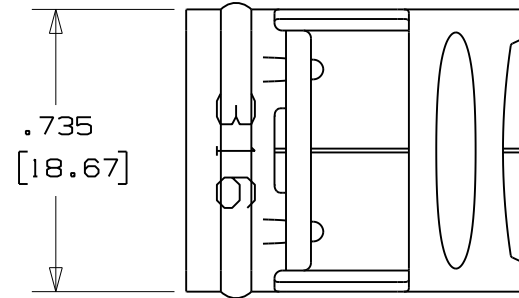

N41149BS\_DC/02A

02A	10/08	JAMB	SKB	ORIG CAD FILE SPEC WAS S41149_02 NOTE 2: APPLICATION TOOL BT1HT REPLACED BY BT2HT				<p>TINLEY PARK, ILLINOIS</p> <p>.625 in [15.88] ENHANCED METAL STRAPPING BUCKLE MSBW63-C4 &amp; MSBW63-C6 CUSTOMER DRAWING</p> <p>Ⓑ</p>
02	10/04	JAMB	EJD	Ⓑ STRAPPING PART NO'S. IN TITLE BLOCK CHANGED TO BUCKLE PART NO'S. DUE TO A TYPING ERROR.	12067			
01	9/04	JAMB	EJD	Ⓐ VOIDED PART NO'S. MS625X15-TSR & MS625X15-TSR316 & REPLACED BY PART NO'S. MS63T15-CR4 & MS63T15-CR6 ON NOTE 1.	12052	CCH	JJB	
00	9/03	BRH	EJD	RELEASED	11154	CCH	JJB	
REV	DATE	BY	CHK	DESCRIPTION	ECN #	PM	CUST	DRAWN BY BRH
								CHK'D EJD
								SCALE 2X
								DRAWING NO. N41149BS_DC